

Enphase S-Series Microinverter and Engage Cable Safety

Important Safety Information (S280-60-LL and S230-60-LL)

This document contains important instructions to use during installation of the Enphase Microinverter™. To reduce the risk of electrical shock, and to ensure the safe installation and operation of the Enphase Microinverter System, follow these instructions. The following safety symbols and information indicate dangerous conditions and important safety instructions.

Product Labels

	WARNING: Hot surface.
	DANGER: Refer to safety instructions.
	DANGER: Risk of electric shock.

Safety and Advisory Symbols

	DANGER! This indicates a hazardous situation, which if not avoided, will result in death or serious injury.
	WARNING! This indicates a situation where failure to follow instructions may be a safety hazard or cause equipment malfunction. Use extreme caution and follow instructions carefully.
	WARNING! This indicates a situation where failure to follow instructions may result in burn injury.
	NOTE: This indicates information particularly important for optimal system operation. Follow instructions carefully.

Safety Instructions















General Safety	
	DANGER: Before installing or using the Enphase Microinverter, read all instructions and cautionary markings in the technical description, on the Enphase Microinverter System, and on the photovoltaic (PV) equipment.
	DANGER: Risk of electric shock. Do not use Enphase equipment in a manner not specified by the manufacturer. Doing so may cause death or injury to persons, or damage to equipment.
	DANGER: Risk of electric shock. Be aware that installation of this equipment includes risk of electric shock. Do not install the AC junction box without first removing AC power from the Enphase System.
	DANGER: Risk of electric shock. The DC conductors of this photovoltaic system are ungrounded and may be energized.
	WARNING: Risk of electric shock. Always de-energize the AC branch circuit before servicing. Never disconnect the DC connectors under load.
	WARNING: Risk of electric shock. Risk of fire. Only use electrical system components approved for wet locations.
	WARNING: Risk of electric shock. Risk of fire. Only qualified personnel should troubleshoot, install, or replace Enphase Microinverters or the Engage Cable and Accessories.
	WARNING: Risk of electric shock. Risk of fire. Ensure that all AC and DC wiring is correct and that none of the AC or DC wires are pinched or damaged. Ensure that all AC junction boxes are properly closed.









	WARNING: Risk of electric shock. Risk of fire. Do not exceed the maximum number of microinverters in an AC branch circuit as listed in this guide. You must protect each microinverter AC branch circuit with a 20A maximum breaker.
	WARNING: Do not connect Enphase Microinverters to the grid or energize the AC circuit(s) until you have completed all of the installation procedures and have received prior approval from the electrical utility company.
	NOTE: To ensure optimal reliability and to meet warranty requirements, install the Enphase Microinverters and Engage Cable according to the instructions in this guide.
	NOTE: Perform all electrical installations in accordance with all applicable local electrical codes and the National Electrical Code (NEC), ANSI/NFPA 70.
	NOTE: The AC and DC connectors on the cabling are rated as a disconnect only when used with an Enphase Microinverter.
	NOTE: Protection against lightning and resulting voltage surge must be in accordance with local standards.
	NOTE: Many PV modules have a central stiffening brace. In these cases, do not position the connector and microinverter at the exact center of the PV module. Instead, position the drop connectors so that the connectors do not conflict with the braces.
	NOTE: Completely install all microinverters and all system AC connections prior to installing the PV modules.



140-00072-02

Safety Instructions, continued

Microinverter Safety	
	WARNING: Risk of skin burn. The body of the Enphase Microinverter is the heat sink. Under normal operating conditions, the temperature is 20°C above ambient, but under extreme conditions the microinverter can reach a temperature of 90°C. To reduce risk of burns, use caution when working with microinverters.
	WARNING: Risk of electric shock. Risk of fire. If the AC cable on the microinverter is damaged, do not install the microinverter.
	WARNING: Risk of electric shock. Risk of fire. Do not attempt to repair the Enphase Microinverter; it contains no user-serviceable parts. If it fails, contact Enphase customer service to obtain an RMA (return merchandise authorization) number and start the replacement process. Tampering with or opening the Enphase Microinverter will void the warranty.
	WARNING: Risk of equipment damage. The S230 and S280 may be paired only with 60-cell PV modules.
	WARNING: Risk of fire. The DC conductors of the PV module must be labeled “PV Wire” or “PV Cable” when paired with the S230 or S280 Microinverters.
	WARNING: You must match the DC operating voltage range of the PV module with the allowable input voltage range of the Enphase Microinverter.
	WARNING: The maximum open circuit voltage of the PV module must not exceed the specified maximum input DC voltage of the Enphase Microinverter.
	WARNING: Risk of equipment damage. The microinverter must be installed under the module, out of rain and sun. Do not mount the microinverter in a position that allows long-term exposure to direct sunlight or in a vertical orientation that allows water to collect in the DC connector recess. Do not install the microinverter vertically with the DC connectors facing up.
	WARNING: Risk of electric shock. Risk of fire. Be aware that only qualified personnel may connect the Enphase Microinverter to the utility grid.
	NOTE: The Enphase Microinverter has field-adjustable voltage and frequency trip points that may need to be set, depending upon local requirements. Only an authorized installer with the permission and following requirements of the local electrical authorities should make adjustments.
	NOTE: The Enphase Microinverter operates with single-phase or three-phase electrical service.
Engage Cable and Accessory Safety	
	DANGER: Risk of electric shock. Do not install the Engage Cable terminator cap while power is connected.
	WARNING: Risk of electric shock. Risk of fire. When stripping the sheath from the Engage Cable, make sure the conductors are not damaged. If the exposed wires are damaged, the system may not function properly.
	WARNING: Risk of electric shock. Risk of fire. Do not leave AC connectors on the Engage Cable uncovered for an extended period. If you do not replace the microinverter immediately, you must cover any unused connector with a sealing cap. Sealing caps may not be reused.

	WARNING: Risk of electric shock. Risk of fire. Make sure protective sealing caps have been installed on all unused AC connectors. Unused AC connectors are live when the system is energized. Sealing caps may not be reused.
	WARNING: Use the terminator only once. If you open the terminator following installation, the latching mechanism is destroyed. Do not reuse the terminator. If the latching mechanism is defective, do not use the terminator. Do not circumvent or manipulate the latching mechanism.
	CAUTION: When installing the Engage Cable, secure any loose cable to minimize tripping hazard
	NOTE: Check the labeling on the Engage Cable drop connectors to be sure that the cable matches the electrical service at the site. Use 208 VAC (208 VAC three-phase) Engage Cable at sites with three-phase 208 VAC service, or use 240 VAC Engage Cable at sites with 240 VAC single-phase service.
	NOTE: There are two release-holes in the drop connector on the cable. These are not for mounting but are used to disconnect the connector. Keep these release holes clear and accessible.
	NOTE: When looping the Engage Cable, do not form loops smaller than 4.75 inches (12 cm) in diameter.
	NOTE: If you need to remove a sealing cap, you must use the Enphase disconnect tool or a #3 Phillips screwdriver. Sealing caps may not be reused.
	NOTE: When installing the Engage Cable and accessories, adhere to the following: <ul style="list-style-type: none"> • Do not expose the terminator cap or cable connections to directed, pressurized liquid (water jets, etc.). • Do not expose the terminator cap or cable connections to continuous immersion. • Do not expose the terminator cap or cable connections to continuous tension (e.g., tension due to pulling or bending the cable near the connection). • Use only the connectors and cables provided. • Do not allow contamination or debris in the connectors. • Use the terminator cap and cable connections only when all parts are present and intact. • Do not install or use in potentially explosive environments. • Do not allow the terminator to come into contact with open flame. • Make sure that all terminator cap seals are seated correctly in the wire organizer. • Fit the terminator cap using only the prescribed tools and in the prescribed manner. • Use the terminator to seal the conductor end of the Engage Cable; no other method is allowed.
	NOTE: Do not use the shipping cap to cover unused connectors. The shipping cap does not provide an adequate environmental seal. Enphase sealing caps are required to protect against moisture ingress.

Installing the Enphase S-Series Microinverters and Engage Cable

The Enphase S-Series Microinverter (S280-60-LL and S230-60-LL) meets the requirements of NEC 690.35.

Enphase Microinverters do not require that you install a GEC between microinverters because the DC circuit is isolated and insulated from ground.

Ground fault protection (GFP) is integrated into the microinverter. To support integrated GFP, use only PV modules equipped with DC cables labeled **PV Wire** or **PV Cable**.

To monitor solar production you must install an Envoy-S. Refer to the *Envoy-S Installation and Operation Manual* or *Quick Install Guide*

Parts and Tools Required

In addition to the S-Series Microinverters, PV modules, and racking, you will need the following.

Enphase Items

- Enphase Envoy-S
- Enphase Installer Toolkit mobil app (optional, but strongly recommended)
- Engage Cable, single-phase 240 VAC or three-phase 208 VAC
- Cable clips
- Sealing caps, as needed (for any unused drops on the Engage Cable)
- Terminators, as needed (one needed at the end of each AC branch circuit)
- Enphase disconnect tool

Other Items

- Outdoor-rated, weather-proof AC junction box(es)
- Gland or strain relief fitting (one per AC junction box)
- Number 2 Phillips screwdriver
- Number 3 Phillips screwdriver
- Torque wrench, sockets, wrenches for mounting hardware
- Adjustable wrench or open-ended wrench (for terminators)
- iOS (v7.0 or later) or Android (v4.2 or later) mobile device installed with Enphase Installer Toolkit

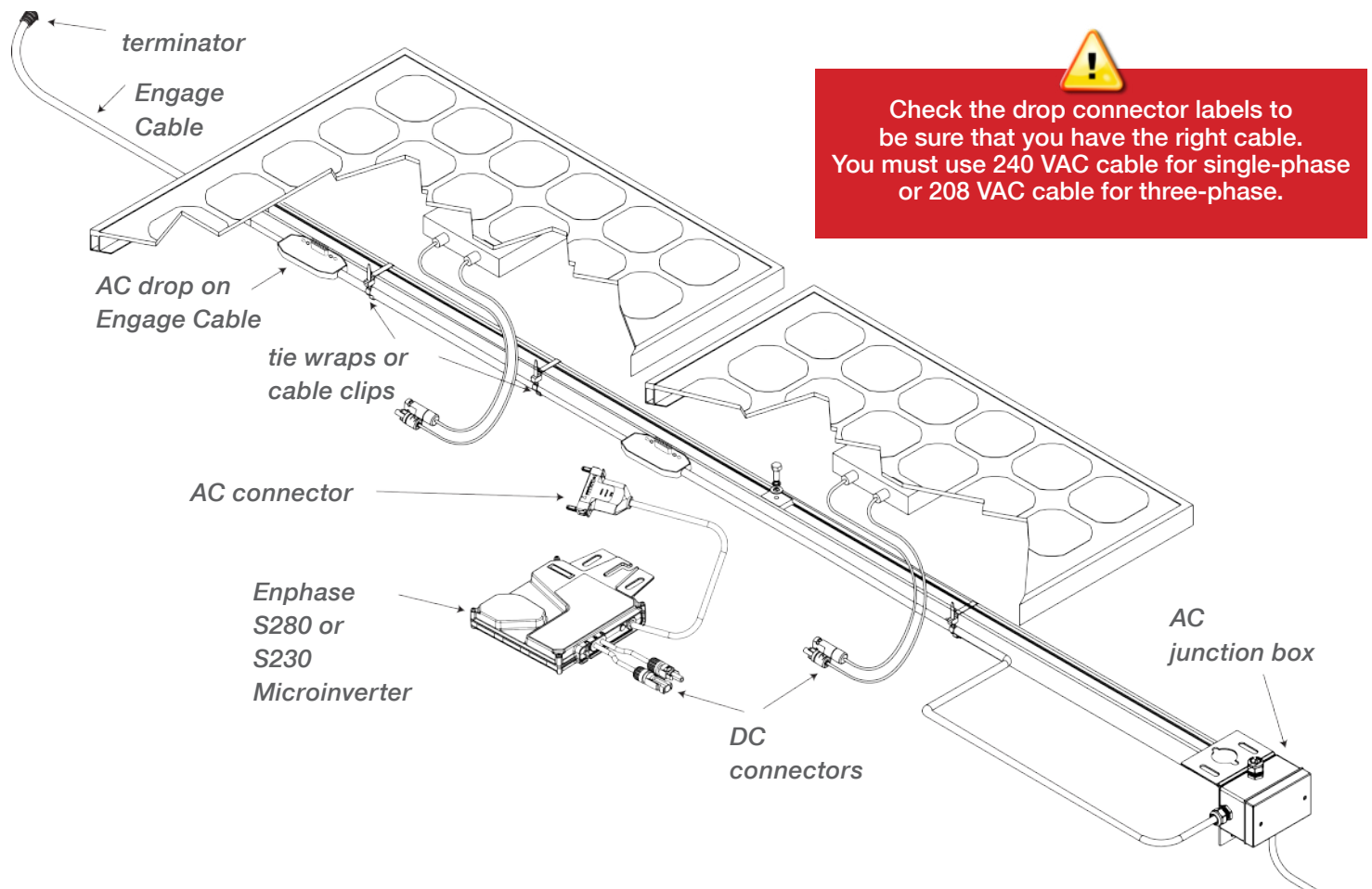

1 Position the Enphase Engage™ Cable

- Plan the cable length to allow drop connectors on the Engage Cable align to with each PV module. Allow extra length for slack, cable turns and any obstructions.
- Cut a length of Engage Cable to meet your planned needs.
- Lay out the cabling along the installed racking for the AC branch circuit.

2 Install an AC Junction Box

- Install an appropriately rated, off-the-shelf junction box at a suitable location on the racking.
- Provide an AC connection from the AC junction box back to the electricity network connection using equipment and practices as required by local jurisdictions.

See notes in **Step Details**.

3 Attach the Microinverters to the PV Racking

- Mark the approximate centers of each PV module on the PV racking. See notes in **Step Details**.

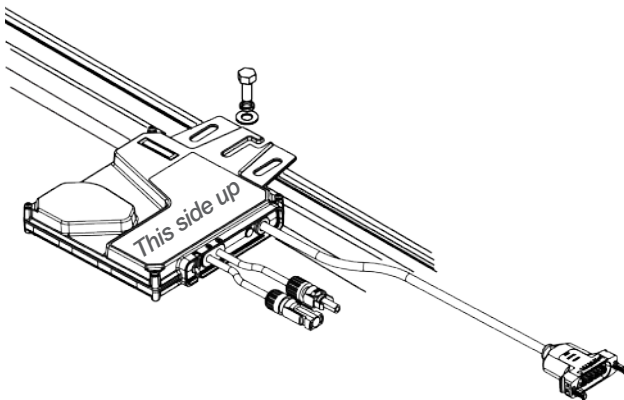

- Mount the microinverter under the PV module, away from rain and sun. Allow a minimum of 1.9 cm (0.75") between the roof and the microinverter. Also allow 1.3 cm (0.50") between the back of the PV module and the top of the microinverter.

Note: Install the microinverter as shown, with the contoured side up. Failure to do so could allow the microinverter to come in contact with the PV module back sheet.



Do not mount the microinverter in a position that allows long-term exposure to direct sunlight or in a vertical orientation that allows water to collect in the cable connector recess.

- Torque the microinverter fasteners as follows.

Do not over torque:

- 5 N m (45-50 in-lbs) for 6 mm (1/4") hardware
- 9 N m (80-85 in-lbs) for 8 mm (5/16") hardware

4 Create an Installation Map

Create a paper installation map to record microinverter serial numbers and position in the array.

- Peel the removable serial number label from each microinverter and affix it to the respective location on the paper installation map.
- Peel the label from the Envoy and affix it to the installation map.

Always keep a copy of the installation map for your records

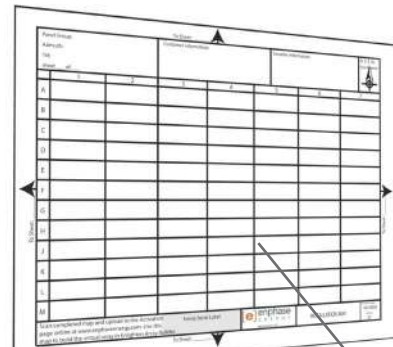

affix
serial number
labels

5 Dress the Cable

- Use cable clips or tie wraps to attach the cable to the racking.

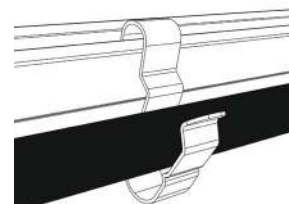

cable clip

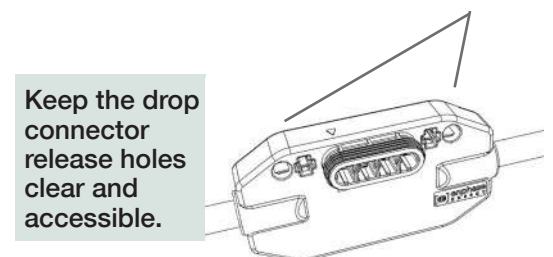

release holes

Keep the drop
connector
release holes
clear and
accessible.

- Dress any excess cabling in loops so that it does not contact the roof. Do not form loops smaller than 4.75 inches (12 cm) in diameter.

QUICK INSTALL GUIDE

6 Connect the Microinverters

- a. Remove and discard the temporary shipping cap from the cable connector and connect the microinverter. Listen for two clicks as the connectors engage.

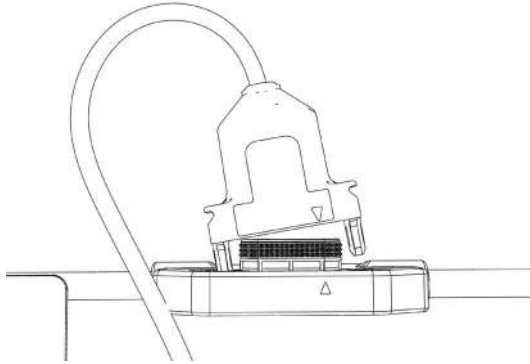

- b. Cover any unused connectors with Enphase Sealing Caps. Listen for two clicks as the connectors engage. **See notes in Step Details.**

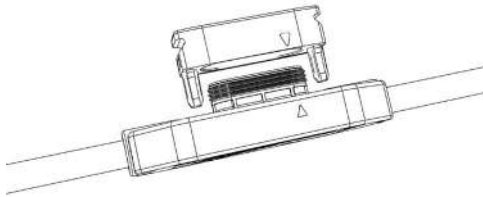

WARNING: Install sealing caps on all unused AC connectors as these become live when the system is energized by the utility. The IP67-rated sealing caps are required for protection against moisture ingress.

- c. Attach the terminated cable end to the PV racking with a cable clip or tie wrap.



Do not use shipping caps to cover unused connectors. The shipping cap does not provide an adequate environmental seal.

7 Terminate the Unused End of the Cable

- a. Remove 60 mm (2.5") of the cable sheath from the conductors.

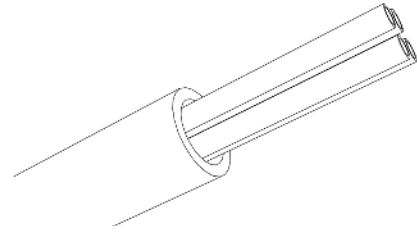

- b. Check that all terminator parts are present.

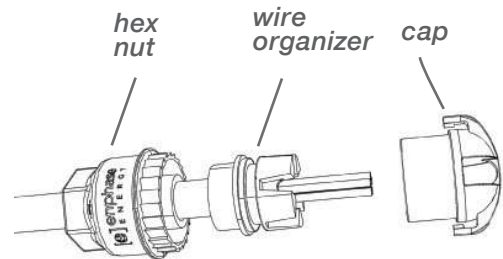

- c. Slide the hex nut onto the cable.
- d. Insert the cable end all the way into the wire organizer (up to the stop).
- e. Attach the cap.

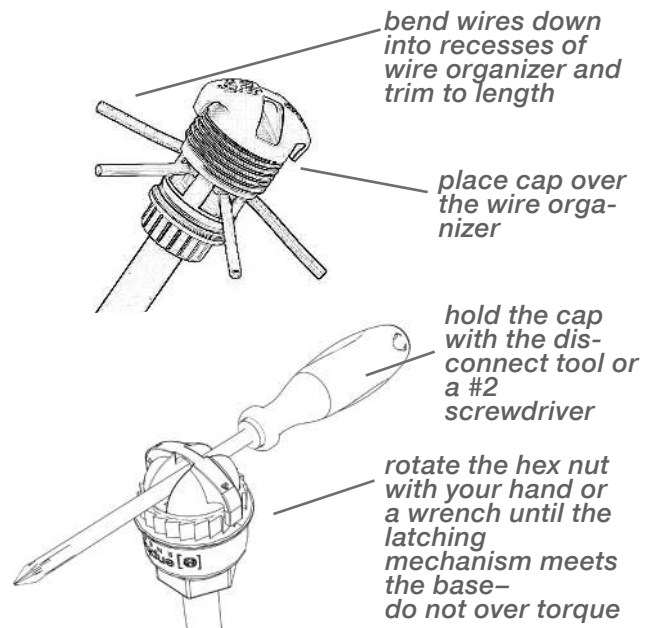

- f. Attach the terminated cable end to the PV racking with a cable clip or tie wrap.



Never unscrew the hex nut. This action can twist and damage the cable.

8 Connect the Cable to the AC Junction Box

Connect the Engage Cable into the AC branch circuit junction box. **See notes in Step Details.**

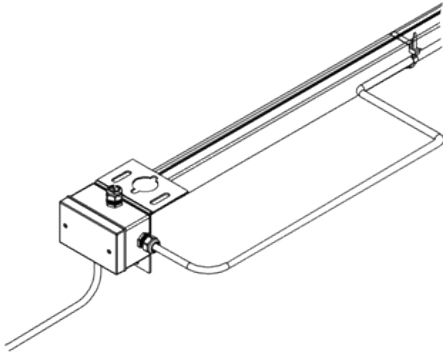

9 Connect the PV Modules

- Mount the PV modules above the microinverters.
- Connect the DC leads of each PV module to the DC input connectors of the corresponding microinverter.
- Check the LED on the side of the microinverter. The LED flashes six times at start up. All green flashes indicate normal start up.

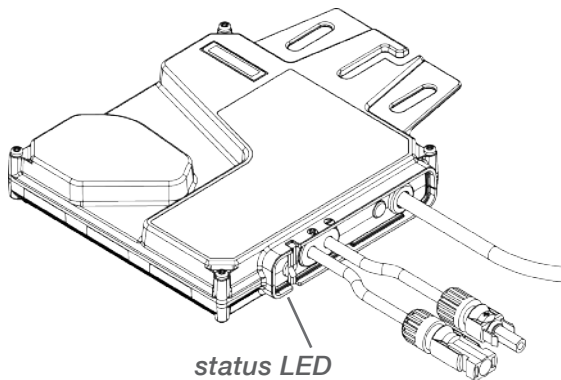

This table lists microinverter LED status for normal operation after startup.

LED	Indicates
Flashing green	Normal operation. AC grid function is normal and there is communication with the Envoy-S.
Flashing orange	The AC grid is normal but there is no communication with the Envoy-S.
Flashing red	The AC grid is not within specification.
Solid red	There is an active DC ground resistance fault.

10 Energize the System

- If applicable, turn ON the AC disconnect or circuit breaker for the branch circuit.
- Turn ON the main utility-grid AC circuit breaker. Your system will start producing power **after a five-minute wait time.**

11 Set Up and Activate System Monitoring

Refer to the *Envoy-S Quick Install Guide* or the *Envoy-S Installation and Operations Manual* to install the Envoy-S and set up system monitoring.

After you have installed the microinverters, the high-level steps to complete the PV installation are:

- Connect the Envoy-S.
- Detect the microinverters.
- Connect to Enlighten.
- Register the system.
- Build the virtual array.

Follow the procedures in the *Envoy-S Quick Install Guide* or the *Envoy-S Installation and Operations Manual* to activate system monitoring and complete the PV installation.

Step Details

2

NOTE: Verify that AC voltage at the site is within range:

240 Volt AC Single-Phase		208 Volt AC Three-Phase	
L1 to L2	211 to 264 VAC	L1 to L2 to L3	183 to 229 VAC
L1, L2, to N	106 to 132 VAC	L1, L2, L3 to N	106 to 132 VAC

WARNING: Only use electrical system components approved for wet locations.

WARNING: Do not exceed the maximum number of microinverters in an AC branch circuit as listed in the table below. Each branch circuit must be protected by a dedicated circuit breaker of 20 A or less.

Service type	Max S230s per branch	Max S280s per branch
240 VAC single-phase	17	14
208 VAC balanced three-phase	24	21

WARNING: Size the AC wire gauge to account for voltage rise for both the branch circuit and all upstream conductors leading back to the PCC. See the Technical Brief on Voltage Rise at <http://www.enphase.com/support>.

3

DANGER: ELECTRIC SHOCK HAZARD. THE DC CONDUCTORS OF THIS PHOTOVOLTAIC SYSTEM ARE UNGROUNDED AND MAY BE ENERGIZED.

WARNING: Allow a minimum of 1.9 cm (0.75") between the roof and the microinverter. Also allow 1.3 cm (0.50") between the back of the PV module and the top of the microinverter.

NOTE: Torque the microinverter fasteners to the values shown. Do not over torque:

- 1/4" mounting hardware – 5 N m (45-50 in-lbs)
- 5/16" mounting hardware – 9 N m (80-85 in-lbs)

NOTE: The AC output neutral is not bonded to ground inside the microinverter.

6

NOTE: To remove a sealing cap or AC connector, you must use the Enphase disconnect tool or a #3 Phillips screwdriver.

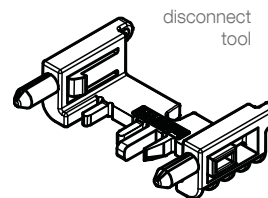

8

NOTE: Engage Cable uses the following wiring scheme.

240 Volt AC Single-Phase Wires	208 Volt AC Three-Phase Wires
Black – L1	Black – L1
Red – L2	Red – L2
White – Neutral	Blue – L3
Green – Ground	White – Neutral
	Green – Ground

The green wire acts as equipment ground (EGC).

Enphase Energy, Inc.

1420 N. McDowell Blvd.

Petaluma, CA 94954

USA

info@enphaseenergy.com

<http://www.enphase.com>



To Sheet: _____ ↗

Panel Group: Azimuth: Tilt: sheet ____ of ____		Customer information:			Installer information:			N S E W (circle one)	
	1	2	3	4	5	6	7		
A									
B									
C									
D									
E									
F									
G									
H									
J									
K									
L									
M									

↖ To Sheet: _____

DOCUMENT NUMBER
140-00003
REVISION
04

INSTALLATION MAP



Envoy Serial Label

Scan completed map and upload it to Enphase. Click "Add a New System" at <https://enlighten.enphaseenergy.com>. Use this map to build the virtual array in Enlighten's Array Builder.

↘ To Sheet: _____